



## **STANDARD DC POWER STEERING**

Mount Pleasant Lane, Lymington, Hampshire SO41 8LS  
Tel: +44 (0)1590 681445 Fax: +44 (0)1590 681446  
[www.hypromarine.com](http://www.hypromarine.com)

# INDEX

<u>Page No.</u>	<u>Contents</u>
1.	DESCRIPTION OF SYSTEM
2.	INSTALLATION <ul style="list-style-type: none"><li>• General Preparation Instructions</li><li>• Rudder Arm Preparation</li></ul>
3.	<ul style="list-style-type: none"><li>• Mounting the HM5090 Power Cylinder/ Servo/Valve Assembly</li><li>• Mounting the Power Pack</li></ul>
4.	<ul style="list-style-type: none"><li>• Mounting the Helm Unit</li><li>• Pipework Installation</li></ul>
5.	<ul style="list-style-type: none"><li>• Electrical Supply</li><li>• Purging the Manual Portion of the System</li></ul>
6.	<ul style="list-style-type: none"><li>• Purging the Power Circuit</li></ul>
7.	<ul style="list-style-type: none"><li>• Commissioning using 12v Power Purger</li></ul>
9.	PREVENTIVE MAINTENANCE <ul style="list-style-type: none"><li>• Every 30 days or before usage of vessel</li><li>• Every 6 months</li><li>• After One Year or First 50 Hours</li><li>• After Two Years or 300 Hours</li></ul>
10.	TROUBLESHOOTING

## DRAWINGS

HM5095	HM3008
HM5090	HM3108
HM5124	

## **DESCRIPTION OF SYSTEM**

The HYPRO MARINE Integrated Power Steering System comprises two distinct hydraulic circuits as illustrated on drawing HM5124:

- a) A hand operated manual system which provides the control
- b) A power circuit to produce the torque required at the rudder

The manual (control) part operates as a standard manual hydraulic steering, with the helm(s) supplying oil to either side of the servo cylinder which is part of the HM5090 Power Cylinder/Servo/Valve assembly. The servo cylinder commands the power cylinder to follow its movement. The power cylinder thus operates in direct response to helm(s) movement, to give a highly responsive steering offering accuracy with minimal wheel effort.

The steering will AUTOMATICALLY revert to manual wheel control if power supply is not available. The helm pumps are provided with integral relief valves which limit the pressure in the manual steering circuit to 70 bar (1000psi).

The HM5095 power pack supplies the power oil for the steering. It can be supplied for operation from either 12 or 24 volt DC supply. The design incorporates two separate electric motor/pumps, and in normal operation both electric motors would operate together to provide the full flow for the steering. The system will operate with reduced response with only one electric motor in operation. It would be recommended that the operation of the electric motors is interlocked with the key start of the engine(s), so that the pumps are only in operation when the engine(s) are running.

The pressure setting of the pumps would normally be preset to 70bar (1000psi), which would meet the requirements of most boats. To meet higher torque requirements, a higher pressure setting of 100 bar (1500psi) is available.

In operation pressure is only developed in the power circuit to bring about changes in rudder position. Under steady conditions dead ahead, oil is freely circulated in the power circuit at minimal pressure. At all times, oil in the power circuit is continuously being filtered.

# **INSTALLATION**

## **GENERAL PREPARATION INSTRUCTIONS**

1. It is recommended that prior to starting any work installing the system, the contents of this manual are fully considered.
2. Before commencing installation, check all components have been received and that all installation fittings are available.
3. It is recommended that fittings are made to component ports prior to installation. In the case of taper threads we would recommend the use of a suitable thread sealant “Loctite 542 Hydraulic Sealant” or equivalent. This sealant should be used sparingly, and care taken to ensure that it does not enter the system. Do not use thread sealant on connections made to hydraulic tube, or hose fittings.
4. It is recommended that all system components are installed prior to running the system tubing. This not only allows the tubing to be run between definite positions, but minimises the chance of incorrect pipework connections. If pipework needs to be pre-installed then an effective means of marking and preventing contaminant entering the system should be adopted. Pipework should be cut cleanly, and it is good practice to blow through each line with clean compressed air before connections are made.

### **CLEANLINESS IS EXTREMELY IMPORTANT**

5. Pipework should be routed to prevent damage from any moving parts or on machinery removal etc. Avoid running pipework close to hot areas, i.e. adjacent to exhaust systems or turbo-chargers. Pipework should be adequately supported and secured avoiding sharp edges or dissimilar metals.

## **RUDDER ARM PREPARATION**

1. The HM5090 Power Cylinder/Servo/Valve Assembly has a nominal operating stroke of 9”.
2. The following chart defines tiller arm radius/required rudder angle.

<b>Rudder Arc</b>	<b>Rudder Arm Length</b>
80°	6.625”
70°	7.437”
60°	8.5”
50°	10.125”

3. Ensure that the attachment bolt or pin to be used matches the ball joint provided on Power Cylinder of the HM5090 unit. Drill and ream the hole in the rudder arm to ensure a close fit.

### MOUNTING THE HM5090 POWER CYLINDER/SERVO/VALVE ASSEMBLY

1. In mounting the HM5090 Cylinder Assembly it is important to ensure that a free passage exists for the flexible hoses which connect to it. In operation these hoses should not be obstructed, or come into contact with any other part.
2. Ensure that the tiller arm can operate freely through its intended angle of operation. When connected to the tiller arm the Cylinder Assembly must be unobstructed throughout the full angle of travel.
3. With the steering cylinder rod attached to the rudder arm, the mounting foot should be positioned such that the HM5090 unit will operate horizontally. When viewed from above it should lie crosswise to the boat when the tiller arm is midway between dead ahead and maximum hard over.

**NOTE: Care should be taken not to damage the cylinder rod as leakage could result.**

4. The mounting bracket to which the HM5090 unit will be connected should have sufficient strength to withstand the forces in operation. The unit can produce a thrust up to 2926 lbs (1330kgs) @ 70 bar or 4389 lbs (1995kgs) @ 100 bar.
5. The specification of the flexible hose used to connect to the unit must provide for a working pressure of at least the relief pressure of the helm and power pack.

### MOUNTING THE POWER PACK

It is beneficial for the power pack to be mounted close to, and if possible, with the oil level above the power cylinder

## MOUNTING THE HELM UNIT

1. The helm unit may be mounted in any position (ensuring fill plug to top) or angle that is best suited to the installation. It is preferable if ports and fittings can be installed facing downwards.
2. Clockwise rotation of the helm shaft gives output of flow from the 'S' port, and anti-clockwise, the 'P' port. The connection from 'R' is made to the appropriate reservoir connection. Port sizes are 1/4" NPTF.
3. Ensure that when installed, the helm shaft does not bind on or interfere with the mounting panel.

## PIPEWORK INSTALLATION

1. In considering the installation, ensure that suitable hoses are incorporated into the system to allow for movement of the HM5090 Cylinder Assembly. Pressure hoses should be rated for a working pressure of at least the relief pressure of the helm and power pack.
2. In choosing rigid tubing for the installation, it is important to consider compatibility of this with the material of construction of the vessel. If flexible hose is to be used for the complete installation, due consideration must be given to the specification of the hose selected to provide minimum expansion of the hose under pressure.

### 3. Pipe Sizes

Typical for boats up to 60ft length:

Steering	5/16" bore*
Power	1/2" bore – assuming length does not exceed 10m

Typical for boats 60-100ft length:

Steering	3/8" bore*
Power	1/2" bore – assuming length does not exceed 10m

\* Selection of hose to provide minimum expansion under pressure is important.

If in doubt on sizing of pipework, please refer to Hypro Marine.

## ELECTRICAL SUPPLY

It is recommended that the electrical supply to the power pack is interlocked with the engine start/run so that the electric motor pumps are only in operation during engine(s) running.

The electrical supply should be adequately protected through a separate circuit breaker rated for maximum current draw of 55 amp/motor @ 1500 psi for 24 volts, and suitably sized for 12 volts.

It is recommended that International Standard ISO 10133 Small Craft – Electrical Systems – Extra-Low Voltage D.C. Installations – is observed for cross-sectional area of conductors and other applicable requirements covered by this Standard.

## PURGING THE MANUAL PORTION OF THE SYSTEM

Fill helm with oil of the recommended specification. We would normally recommend the use of oil to ISO-VG10. In the case of a dual station steering, firstly ensure that the lower helm is fitted with a non-vented fill plug. Fill oil at the upper helm, loosening non-vented fill plug at the lower helm to ensure the lower helm is primed with oil.

This manual (command) part of the system operates as a normal manual hydraulic circuit and can be commissioned following normal procedures using the bleed fittings included with the HM5090 assembly.

The time taken on this procedure can be reduced with the use of a 12v Power Purger.

As a final step, operate the helm at any position to each end of stroke to verify a definite stop is achieved. It is beneficial to operate the wheel beyond the normal end stop for approximately half a turn to verify the operation of the relief valves incorporated in the system.

## HELM FLUID LEVEL CHECK SHOULD ONLY BE DONE

## WHEN HM5090 CYLINDER ROD IS FULLY RETRACTED

## PURGING THE POWER CIRCUIT

1. Remove the fill cap from the top of the oil reservoir. Fill the reservoir to the maximum level on the level gauge with oil of the recommended specification. We would normally recommend the use of oil to ISO-VG10. For reservoirs not provided with a separate filler, the filter cover can be removed for the purpose of filling the reservoir.
2. Start the power pump(s), observing the fluid in the reservoir. If it drops to below the minimum level of the level gauge, shut down pump(s), refill the reservoir, and re-start the pump(s).
3. From any helm, slowly steer hard-over to hard-over several times. This will essentially self purge the power portion of the system.
4. There should be approximately 4 turns from hard-over to hard-over. If significantly greater, the power pump(s) should be shut down and the above sequence for purging the manual portion of the system repeated.
5. Re-check the reservoir oil level and fill if necessary.
6. To visually observe any future leakage, it is best to mark the stabilised fluid level on the level gauge.

IN NORMAL OPERATION THERE SHOULD BE NO CONTACT WITH THE RUDDER STOPS. RUDDER STOPS SHOULD BE SET TO HAVE A NOMINAL  $\frac{1}{8}$ " OPERATING CLEARANCE, SET AT BOTH FULL HARD-OVER POSITIONS, WITH THE SYSTEM IN THE POWER MODE.



## COMMISSIONING USING 12V POWER PURGER

1. Screw in helm adaptors into both top and bottom helm pumps.
2. Connect helm hose from purger onto lower helm.
3. Connect cylinder hoses onto bleed tees fitted on servo cylinder and undo bleed nut 1/2 - 3/4 turn (do not use bleed elbow that is already fitted to valve block - this is not required for bleeding with a power purger and will be removed and plugged on future cylinders).
4. Switch on power purger and allow to run until air bubbles have cleared.
5. Turn wheel to port or starboard until cylinder is at the end of its stroke and leave to clear air bubbles again. (It may be necessary to assist the cylinder by pushing the rod in the direction required while the wheel is being turned).
6. When pipes are clear of air bubbles turn the wheel in the opposite direction until cylinder is at the end of stroke and then wait until air bubbles have cleared, again, assist the cylinder by hand if necessary.
7. With the purger still running, operate autopilot pump for a few seconds in either direction to bleed this part of the circuit.
8. Switch purger off, disconnect helm hose and connect to top helm.
9. Repeat process from 4 - 6.
10. Repeat steps 2 and 4 turning the wheel from lock to lock until air bubbles clear.
11. Switch off purger but leave helm hose connected.
12. Close bleed nuts on cylinder bleeds.
13. Turn wheel so that cylinder rod is fully in (not extended).
14. Disconnect helm purger hose from upper helm.
15. Remove purger hose adaptor from lower helm first and fit non vented plug.

16. Remove purger hose adaptor from upper helm, check fluid level which should be about 1/4" below the thread and then fit vented plug when rod retracted.
17. Bleed the power side of the steering by filling HM5095 power pack reservoir to max. and then run the power pack whilst turning the wheel hard over to hard over half a dozen times.
18. Switch off HM5095 power pack - check fluid level and top up as necessary.

**Note: If power pack is wired in prior to bleeding process 1 – 16, steps 17 and 18 can be carried out before 1 – 16, as with the power side bled and the power pack running it will help to move the cylinder without manual assistance and speed up the bleed process.**

This completes the process and should give you a fully bled system.

## **PREVENTIVE MAINTENANCE**

### **Every 30 Days or Before Usage of Vessel**

1. Check hydraulic fluid level in HM5095 power pack, which should show full on the level gauge. There may be a small reduction in level during operation of the system which should recover shortly after shutdown.
2. Check fluid level in upper helm with HM5090 cylinder rod fully retracted.

### **Every 6 Months**

1. Check fluid level in the reservoir.
2. Check pivot points in the system are suitably greased or oiled. The HM5090 unit is provided with a grease maintenance point.
3. Check mounting bolt of steering unit tiller arm, and rear mounting bolts to vessel structure are correctly tightened.
4. Ensure that the ball joint on HM5090 unit is operating freely and is suitably greased. It is suggested that if a tie bar is fitted on the vessel, this is checked at this point.
5. Ensure that there is no wear in either the ball joint or the rear pivot mounting of the HM5090 unit.
6. Check all hoses on the installation for possible chafing or scuffing against one another, or against part of the vessel. Replace if braiding under the rubber sheath is exposed.

### **After One Year or First 50 Hours**

Additional to 6 month check, replace the micro filter cartridge and refill system oil as necessary.

### **After Two Years or 300 Hours**

Additional to 6 month check, replace micro filter cartridge and carry out complete oil change to the system. Re-purge power circuit. Refer to P.7 "Purging the Power Circuit".

## TROUBLESHOOTING

<b>PROBLEM</b>	<b>POSSIBLE CAUSE</b>	<b>SOLUTION</b>
One helm unit will operate the rudder, but the other has no effect.	1. Air lock at helm. 2. Contaminant in pilot check valve of correctly functioning helm.	1. Crack fittings at helm. 2. Replace or have repair carried out on the helm.
Operation at one helm causes other station helm to operate.	Contaminant in pilot check valve of freewheeling helm unit.	Replace or have repair carried out on the freewheeling helm.
Rudder will not retain set position.	Leaking in relief valve (manual circuit).	Carry out manual system purging to displace possible contaminant.  Alternatively, refurbish helm pumps.
System appears not purged after commissioning.	Air saturation in oil.	Re-purge after reasonable settling period.
Power pump(s) noisy in operation.	Suction cavitation at pump(s).	Clean suction strainer on pump(s).
Steering locks at hard-over.	Excess friction in servo.	Grease, lubricate, or correct possible off-set loading.
Operation of one helm gives opposite command to the other.	Helm ports 'P' and 'S' cross-connected at one helm station.	Reverse pipe connection to 'P' and 'S' at the station(s) that is in error.
Operation at helm(s) gives incorrect steering direction.	Helm(s) ports 'P' and 'S' cross connected with 'H1' and 'H2' of HM5090	Reverse pipe connections 'H1' and 'H2' at HM5090.
Helm(s) pumps in one direction but not in the other.	1. Symptom at one helm indicates helm fault. 2. Symptom at both helms indicates valve fault in HM5090	1. Replace or have repair carried out on the helm. 2. Refurbish HM5090 valve.
Helm unit(s) give excessive turns for lock to lock.	Air in system.	Re-purge system.
Loss of fluid and pressure in the reservoir.	Leak in the system.	Check all connections. Repair as necessary.

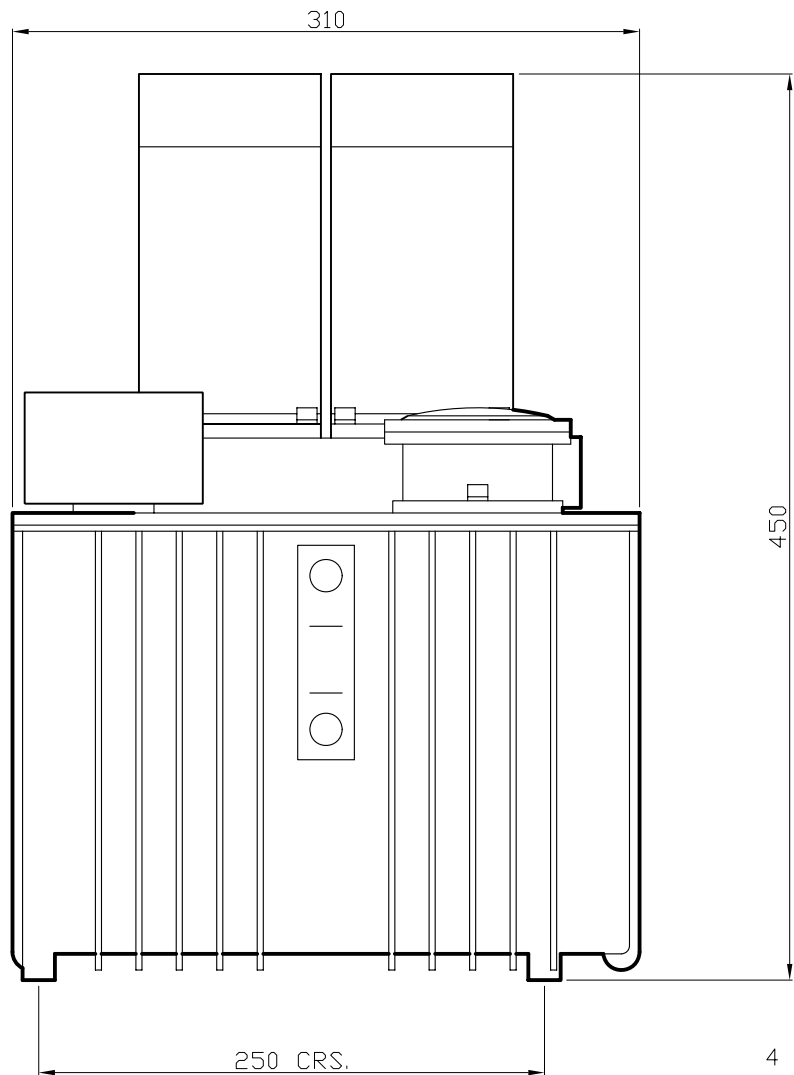

PORT 'SP' 3/8"-NPTF  
TO 'SP' ON SERVO CYL.

RETURN FROM 'ST'  
ON SERVO CYL.  
THRO' FILTER  
3/8"-NPTF

4 OFF MOUNTING HOLES  
M8 x 1.25 x 12 DP.

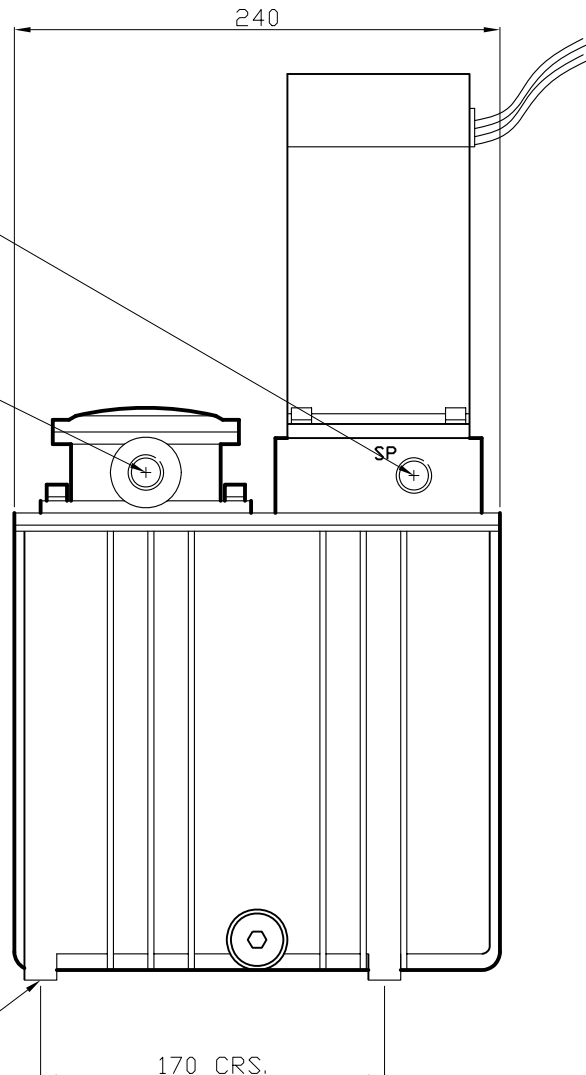

CURRENT DRAW: TYP. 70A MAX. @ 1000PSI  
TYP. 25A NO LOAD  
NOM. FLOW: 5LPM

OIL CAPACITY: 10 LITRE TO MARK  
WEIGHT: 15kg WITHOUT OIL

THIS DRAWING IS THE PROPERTY OF HYPRO MARINE AND MUST NOT  
BE COPIED IN WHOLE OR PART WITHOUT WRITTEN CONSENT

# Hypro Marine

TITLE: **ELECTRO-HYDRAULIC  
PUMP UNIT**  
24Vd.c., 500W  
CONTINUOUS RUNNING

DRAWN: MC  
DATE: 3/2/07  
THIRD ANGLE  
PROJECTION

DRG. NO:  
**HM5095**  
ISSUE: 1 - ORIGINAL

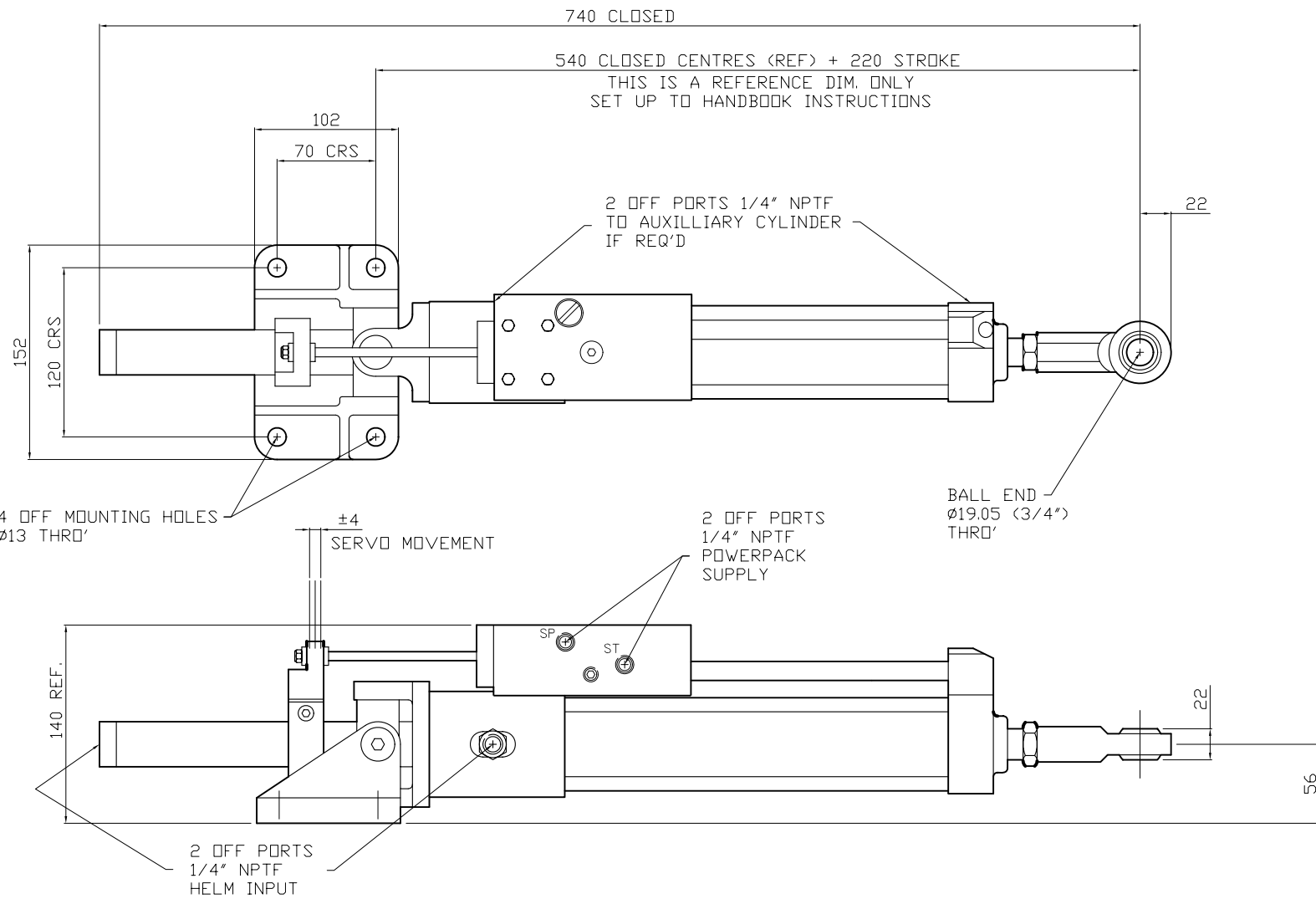

THRUST: 2930 lbf (1332 Kgf) @ 1000PSI (70 BAR). MAX. 1500PSI (100 BAR).

SWEPT VOLUME:- COMMAND 6.1 CUIN., POWER 28.4 CUIN.

WEIGHT - 13 KG

THIS DRAWING IS THE PROPERTY OF HYPRO MARINE AND MUST NOT BE COPIED IN WHOLE OR PART WITHOUT WRITTEN CONSENT

TITLE:  
**INTEGRATED SERVO/POWER  
 CYLINDER  
 DC POWER PACK DERIVATIVE**

DRAWN: MC  
 DATE: 7/11/06  
 THIRD ANGLE  
 PROJECTION

DRG. NO:  
**HM5090**  
 ISSUE: 1 - ORIGINAL

**Hypro Marine**

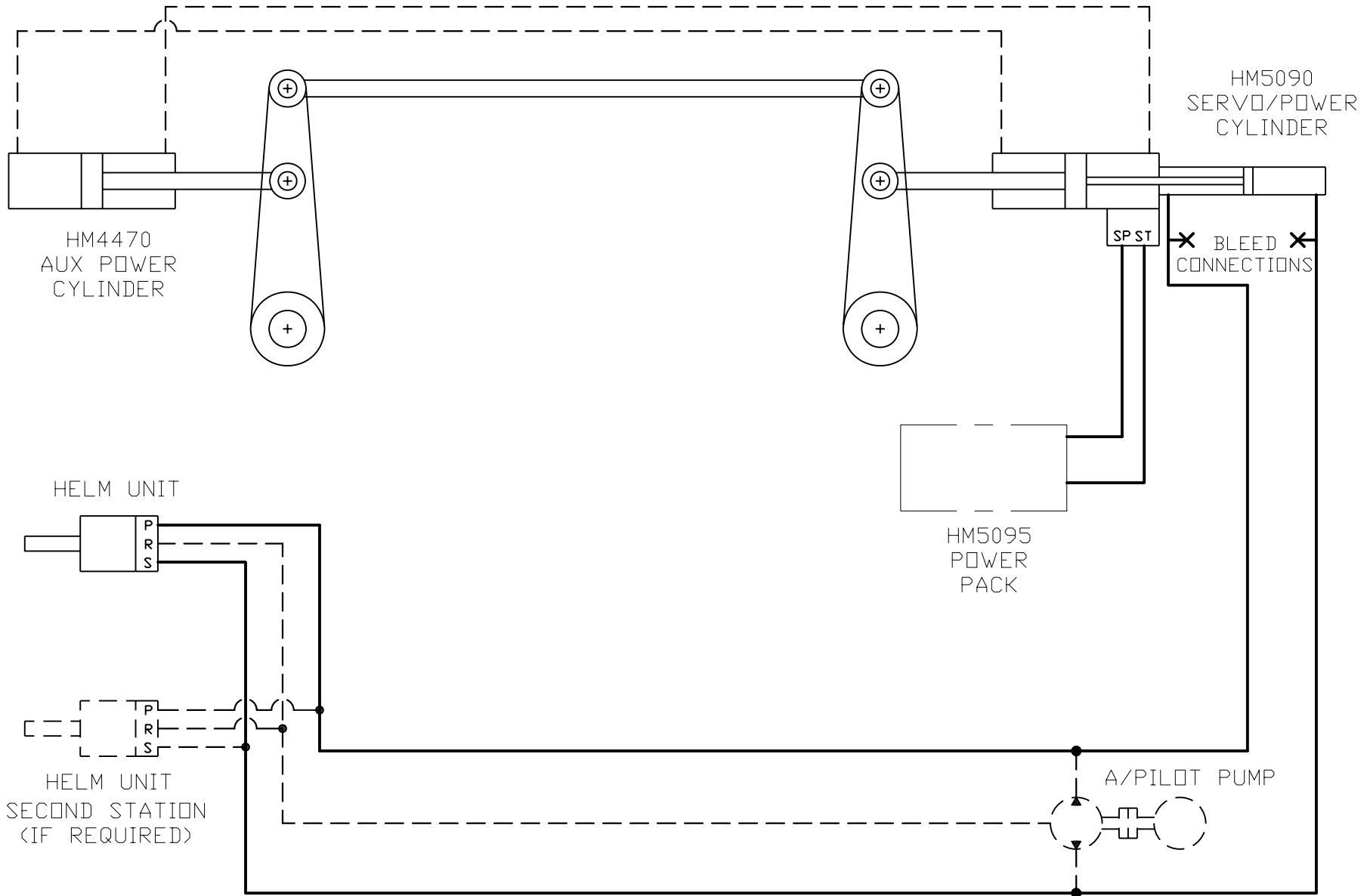

**Hypro**  
MARINE

TITLE: HYDRAULIC CIRCUIT  
DC POWER STEERING  
(LARGE CYLINDER)

DRAWN: MC  
DATE: 20/2/07

DRG. NO:  
HM5124

THIS DRAWING IS THE PROPERTY OF HYPRO MARINE AND MUST NOT BE COPIED IN WHOLE OR PART WITHOUT WRITTEN CONSENT

ISSUE: 1 - ORIGINAL

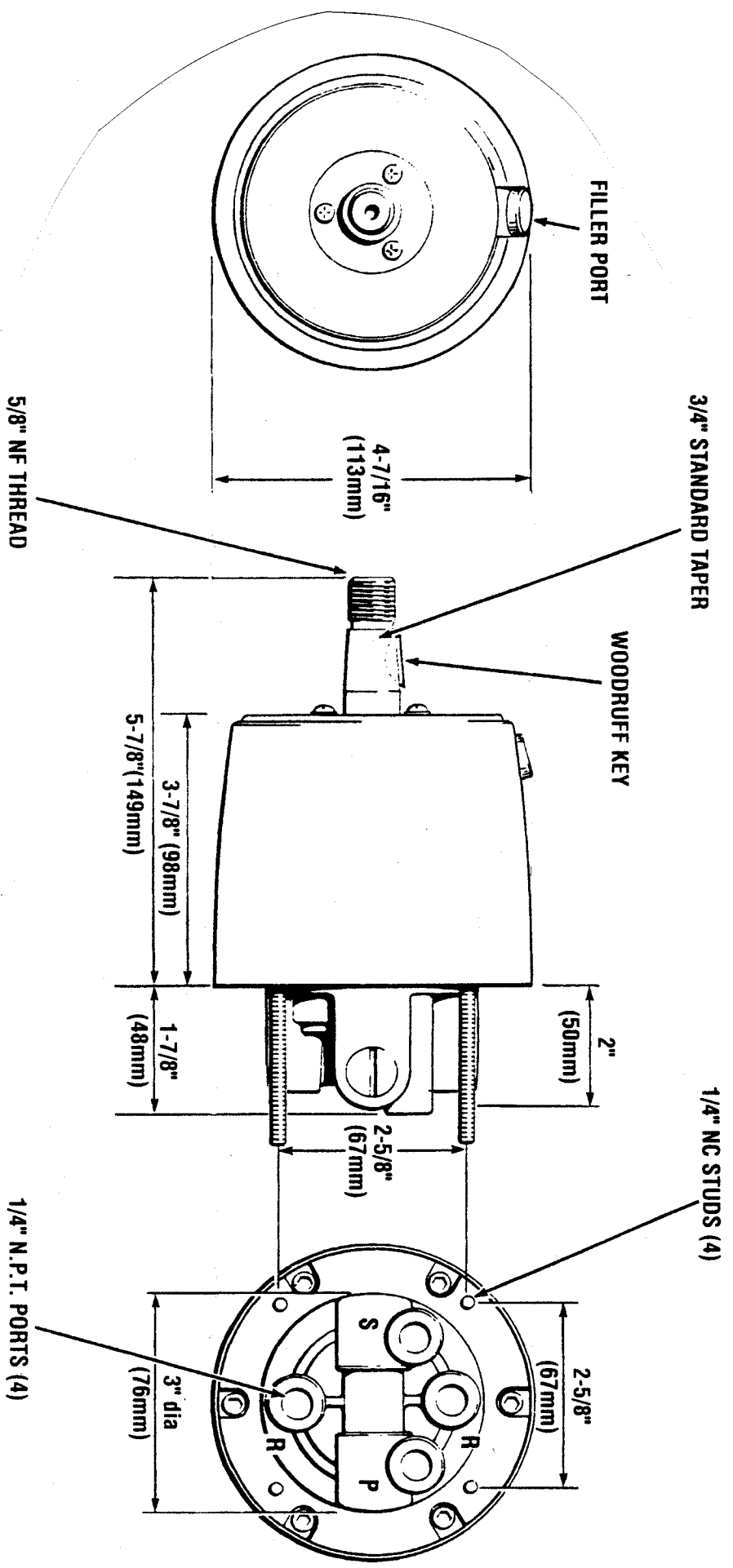

SIMILAR HELM UNITS:  
 HM3006 - 1.7 CUIN./REV  
 HM3007 - 2.4 CUIN./REV

FOR NON VENTED HELM,  
 REPLACE FILL PLUG WITH  
 NON VENTED TYPE - HM3109

WEIGHT - 3.5KG

THIS DRAWING IS THE PROPERTY OF HYPRO MARINE AND MUST NOT  
 BE COPIED IN WHOLE OR PART WITHOUT WRITTEN CONSENT

TITLE:

FIXED HELM UNIT  
 2.0 CUIN./REV

DRAWN: MC

DATE: 15/11/05

THIRD ANGLE  
 PROJECTION

DRG. NO:

HM3008

ISSUE: 2 - 10127

**Hypro Marine**



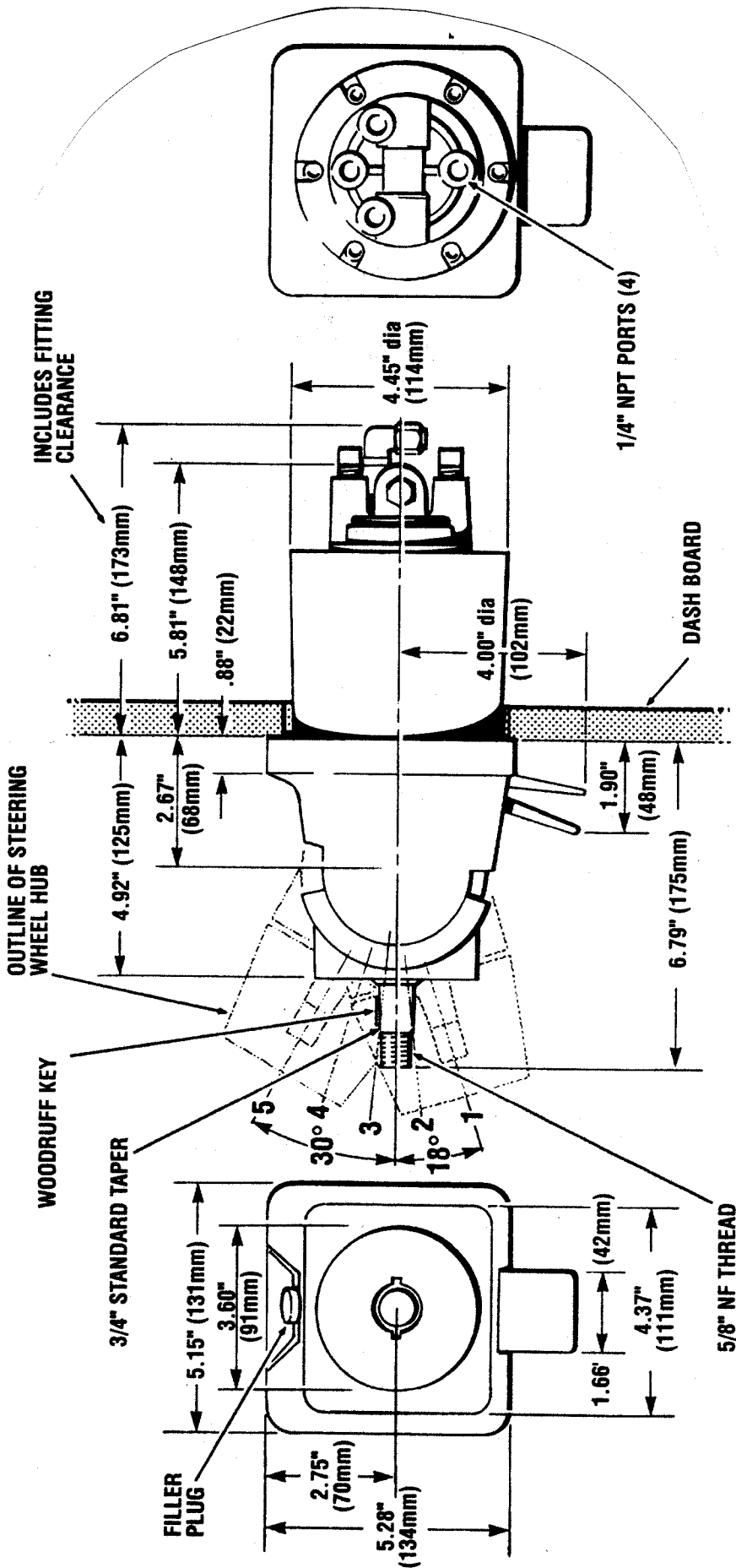

SIMILAR HELM UNITS:  
 HM3002 - 1.7 CUIN./REV  
 HM3003 - 2.4 CUIN./REV

FOR NON VENTED HELM,  
 REPLACE FILL PLUG WITH  
 NON VENTED TYPE - HM3109

WEIGHT - 5.5KG

THIS DRAWING IS THE PROPERTY OF HYPRO MARINE AND MUST NOT BE COPIED IN WHOLE OR PART WITHOUT WRITTEN CONSENT

**Hypro Marine**

TITLE:  
 TILT HELM UNIT  
 2.0 CUIN./REV

DRAWN: MC  
 DATE: 15/11/05  
 THIRD ANGLE PROJECTION

DRG. NO: HM3108  
 ISSUE: 2 - 10128